

INDEX

SHEET NO.	SUBJECT
1	Index
2	Traffic Control Signs
3	Traffic Control Signs
4	Traffic Control Sign Design Details
5	Traffic Control Sign Design Details
6	Traffic Control Sign Design Details
7	Temporary Panel Sign Breakaway Post Installation
8	Wood Post Design For Temporary Panel Signs

GENERAL NOTES:

1. The minimum vertical and horizontal clearances for construction signs shall be as shown on Standard Drawing E 801-TCDV-05.
2. The minimum horizontal clearance for construction signs on curbed roadway sections shall be 2'-0" from the face of the curb to the near edge of the sign.
3. The minimum depth for wood or steel posts shall be 4 ft.
4. See Standard Drawing E 801-TCDV-08 for U-Channel Steel Post Splice Detail.

INDIANA DEPARTMENT OF TRANSPORTATION

TRAFFIC CONTROL SIGNS
INDEX SHEET

SEPTEMBER 2016

STANDARD DRAWING NO. E 801-TCSN-01

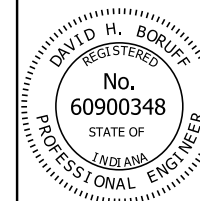

/s/ David H. Boruff 02/25/16
DESIGN STANDARDS ENGINEER DATE

/s/ Mark A. Miller 02/25/16
CHIEF ENGINEER DATE



XW20-1
XW20-1-A



XW21-8a
XW21-8a-A



XW21-8b
XW21-8b-A



XW20-1a



XW2-6a
XW2-6a-A
XW2-6a-B



XW2-6b
XW2-6b-A
XW2-6b-B



XW103-1

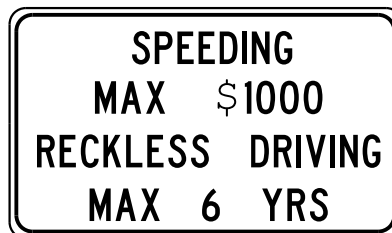

XW2-6
XW2-6-A



XG20-2



XW3-4S

NOTES:

1. See Standard Drawing E 801-TCSN-01 for general notes.
- ② Sign Shall be removed, covered or turned to face away from the roadway during non-working hours.
- ③ Sign may be ordered to read "500 FT", "1000 FT", or "1500 FT" in place of the word "AHEAD". Such Signs may be used in place of or in conjunction with the indicated sign.
- ④ Shaded text Indicates message content that must be varied to reflect site conditions.

INDIANA DEPARTMENT OF TRANSPORTATION

TRAFFIC CONTROL SIGNS

SEPTEMBER 2016

STANDARD DRAWING NO. E 801-TCSN-02

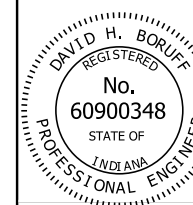

/s/ David H. Boruff 03/24/16
DESIGN STANDARDS ENGINEER DATE

/s/ Mark A. Miller 03/24/16
CHIEF HIGHWAY ENGINEER DATE



XW105-1-A

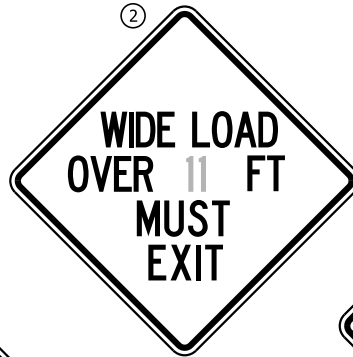

XW20-YWR(B)



XW20-YWR(A)

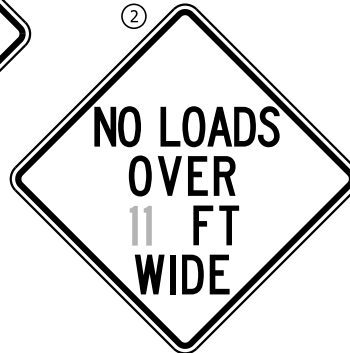

XW20-YWL(C)



XW106-2-A



XW106-1-A

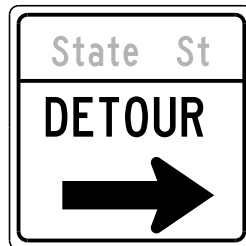

XM4-9d

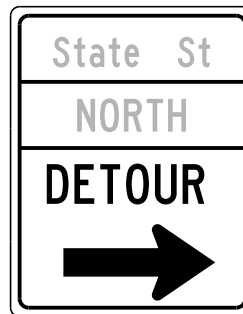

XM4-9e

NOTES:

- 1. See Standard Drawing E 801-TCSN-01 for general notes.
- ② Shaded text indicates message content that must be varied to reflect site conditions.



XW109-1

INDIANA DEPARTMENT OF TRANSPORTATION	
TRAFFIC CONTROL SIGNS	
SEPTEMBER 2016	
STANDARD DRAWING NO.	E 801-TCSN-03
	<i>/s/ David H. Boruff</i> 03/24/16 DESIGN STANDARDS ENGINEER DATE
	<i>/s/ Mark A. Miller</i> 03/24/16 CHIEF HIGHWAY ENGINEER DATE

① ①

SIGN NUMBER	IMUTCD CODE	SIGN MESSAGE	POST DESIGN		SIGN SIZE	SIGN COLOR		BORDER WIDTH	MARGIN WIDTH	LETTER HEIGHT SERIES - LINE 1	LETTER HEIGHT SERIES - LINE 2	LETTER HEIGHT SERIES - LINE 3	WORD OR LINE	PCT.	CORNER RADIUS	NO. OF POSTS	
			4 X 4 WOOD	STEEL		BACKGROUND	COPY									1	2
R2-1	R2-1	Speed Limit ____	*	A	24 X 30	White	Black										X
R2-1-B	R2-1	Speed Limit ____	*	B	48 X 60	White	Black										X
R3-2-A (R or L)	R3-2	(Movement Prohibition)	*	A	30 X 30	White	Black										X
R3-2-C (R or L)	R3-2	(Movement Prohibition)	*	B	48 X 48	White	Black										X
R4-1	R4-1	Do Not Pass	*	A	24 X 30	White	Black										X
R4-1-B	R4-1	Do Not Pass	*	B	48 X 60	White	Black										X
R5-1-A	R5-1	Do Not Enter	*	A	36 X 36	Red	White										X
R5-1-B	R5-1	Do Not Enter	*	B	48 X 48	Red	White										X
R6-1 (R or L)	R6-1	One Way (Inside White Arrow)	*	A	36 X 12	White	Black										X
R6-2-A (R or L)	R6-2	One Way (Above White Arrow)	*	A	24 X 30	Black & White	Black										X
R11-2	R11-2	Road Closed	*	B	48 X 30	White	Black										X
R11-3	R11-3	Road Closed - Local Traffic Only	*	B	60 X 30	White	Black										X
R11-4	R11-4	Road Closed to Thru Traffic	*	B	60 X 30	White	Black										X
R12-1	R12-1	Weight Limit ____ Tons	*	A	24 X 30	White	Black										X
R12-1-A	R12-1	Weight Limit ____ Tons	-	B	36 X 48	White	Black										X
S4-4	S4-4	When Flashing Plaque	*	-	48 X 20	White	Black										-
XW1-1-A (R or L)	W1-1	(Turn Symbol)	*	A	36 X 36	Orange	Black										X
XW1-1-B (R or L)	W1-1	(Turn Symbol)	*	B	48 X 48	Orange	Black										X
XW1-2-A (R or L)	W1-2	(Curve Symbol)	*	A	36 X 36	Orange	Black										X
XW1-2-B (R or L)	W1-2	(Curve Symbol)	*	B	48 X 48	Orange	Black										X
XW1-3-A (R or L)	W1-3	(Reverse Turn Symbol)	*	A	36 X 36	Orange	Black										X
XW1-3-B (R or L)	W1-3	(Reverse Turn Symbol)	*	B	48 X 48	Orange	Black										X
XW1-4-A (R or L)	W1-4	(Reverse Curve Symbol)	*	A	36 X 36	Orange	Black										X
XW1-4-B (R or L)	W1-4	(Reverse Curve Symbol)	*	B	48 X 48	Orange	Black										X
XW1-6	W1-6	(Single Headed Arrow)	*	B	48 X 24	Orange	Black										X
XW1-6-A	W1-6	(Single Headed Arrow)	*	B	60 X 30	Orange	Black										X
XW2-6	XW2-6	Worksite Added Penalty	*	B	60 X 36	Orange	Black	7/8	5/8	5 - Series C	5 - Series C	5 - Series C	5 - Series C		2 1/4		X
XW2-6-A	XW2-6	Worksite Added Penalty	*	B	78 X 42	Orange	Black	7/8	5/8	6 - Series D	6 - Series D	6 - Series D	6 - Series D		2 1/4		X
XW2-6a	XW2-6a	Speeding Max \$1000	*	A	30 X 30	Orange	Black	3/4	1/2	4 - Series C	4 - Series C			1 7/8	X		
XW2-6a-A	XW2-6a	Speeding Max \$1000	*	A	36 X 36	Orange	Black	7/8	5/8	5 - Series C	5 - Series C			2 1/4		X	
XW2-6a-B	XW2-6a	Speeding Max \$1000	*	B	48 X 48	Orange	Black	1 1/4	3/4	6 - Series D	6 - Series D			3		X	
XW2-6b	XW2-6b	Reckless Driving Max 8 Yrs	*	A	30 X 30	Orange	Black	3/4	1/2	4 - Series C	4 - Series C			1 7/8	X		
XW2-6b-A	XW2-6b	Reckless Driving Max 8 Yrs	*	A	36 X 36	Orange	Black	7/8	5/8	5 - Series C	5 - Series C			2 1/4		X	
XW2-6b-B	XW2-6b	Reckless Driving Max 8 Yrs	*	B	48 X 48	Orange	Black	1 1/4	3/4	6 - Series D	6 - Series D			3		X	

*Wood post permitted.

NOTES:

- ① Spacing between letters of this word or line shall be reduced by this percentage as shown in the FHWA document, *Standard Highway Signs*.
- 2. See Standard Drawing E 801-TCSN-01 for additional general notes.
- 3. All dimensions are in inches.

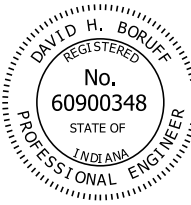
INDIANA DEPARTMENT OF TRANSPORTATION	
TRAFFIC CONTROL SIGN DESIGN DETAILS	
SEPTEMBER 2016	
STANDARD DRAWING NO.	E 801-TCSN-04
	<i>/s/ David H. Boruff</i> 03/24/16 DESIGN STANDARDS ENGINEER DATE
	<i>/s/ Mark A. Miller</i> 03/24/16 CHIEF ENGINEER DATE

① ①

SIGN NUMBER	IMUTCD CODE	SIGN MESSAGE	POST DESIGN		SIGN SIZE	SIGN COLOR		BORDER WIDTH	MARGIN WIDTH	LETTER HEIGHT SERIES - LINE 1	LETTER HEIGHT SERIES - LINE 2	LETTER HEIGHT SERIES - LINE 3	WORD OR LINE	PCT.	CORNER RADIUS	NO. OF POSTS			
			4 X 4 WOOD	STEEL		BACKGROUND	COPY									1	2		
XW3-4S	-	Overhead Sign Installation	*	B	60 x 24	Orange	Black	1/2	3/8	6 - Series C	6 - Series C				1 1/2		X		
XW3-5-A	W3-5	(Reduced Speed Limit Ahead)	*	A	36 X 36	Orange	Black	See FHWA publication Standard Highway Signs for fabrication details											X
XW3-5-B	W3-5	(Reduced Speed Limit Ahead)	*	B	48 X 48	Orange	Black	See FHWA publication Standard Highway Signs for fabrication details											X
XW3-5a-A	W3-5	(Reduced Speed Limit Ahead)	*	A	36 X 36	Orange	Black	See FHWA publication Standard Highway Signs for fabrication details											X
XW3-5a-B	W3-5	(Reduced Speed Limit Ahead)	*	B	48 X 48	Orange	Black	See FHWA publication Standard Highway Signs for fabrication details											X
XW4-2 (R or L)	W4-2	(Lane Ends Merge Symbol)	*	A	36 X 36	Orange	Black	See FHWA publication Standard Highway Signs for fabrication details											X
XW4-2-A (R or L)	W4-2	(Lane Ends Merge Symbol)	*	B	48 X 48	Orange	Black	See FHWA publication Standard Highway Signs for fabrication details											X
XW6-2a-A	W6-2	(Divided Highway Ends Symbol)	*	A	36 X 36	Orange	Black	See FHWA publication Standard Highway Signs for fabrication details											X
XW6-2a-B	W6-2	(Divided Highway Ends Symbol)	*	B	48 X 48	Orange	Black	See FHWA publication Standard Highway Signs for fabrication details											X
XW6-3-B	W6-3	(Two Way Traffic Symbol)	*	B	48 X 48	Orange	Black	See FHWA publication Standard Highway Signs for fabrication details											X
XW8-1-A	W8-1	Bump	*	A	36 X 36	Orange	Black	See FHWA publication Standard Highway Signs for fabrication details											X
XW8-1-B	W8-1	Bump	*	B	48 X 48	Orange	Black	See FHWA publication Standard Highway Signs for fabrication details											X
XW8-2-A	W8-2	Dip	*	A	36 X 36	Orange	Black	See FHWA publication Standard Highway Signs for fabrication details											X
XW8-2-B	W8-2	Dip	*	B	48 X 48	Orange	Black	See FHWA publication Standard Highway Signs for fabrication details											X
XW8-3-A	W8-3	Pavement Ends	*	A	36 X 36	Orange	Black	See FHWA publication Standard Highway Signs for fabrication details											X
XW8-4-A	W8-4	Soft Shoulder	*	A	36 X 36	Orange	Black	See FHWA publication Standard Highway Signs for fabrication details											X
XW8-4-B	W8-4	Soft Shoulder	*	B	48 X 48	Orange	Black	See FHWA publication Standard Highway Signs for fabrication details											X
XW8-6-A	W8-6	Truck Crossing	*	A	36 X 36	Orange	Black	See FHWA publication Standard Highway Signs for fabrication details											X
XW8-6-B	W8-6	Truck Crossing	*	B	48 X 48	Orange	Black	See FHWA publication Standard Highway Signs for fabrication details											X
XW9-1-A (R or L)	W9-1	Lane Ends	*	A	36 X 36	Orange	Black	See FHWA publication Standard Highway Signs for fabrication details											X
XW9-1-B (R or L)	W9-1	Lane Ends	*	B	48 X 48	Orange	Black	See FHWA publication Standard Highway Signs for fabrication details											X
XW9-2-B (R or L)	W9-2	Lane Ends Merge	*	B	48 X 48	Orange	Black	See FHWA publication Standard Highway Signs for fabrication details											X
XW12-1-C	W12-1	Double Arrow	*	B	48 X 48	Orange	Black	See FHWA publication Standard Highway Signs for fabrication details											X
XW13-1-A	W13-1	Advisory Speed Plaque	*	A	36 X 36	Orange	Black	See FHWA publication Standard Highway Signs for fabrication details											-
XW20-1	W20-1	Road Construction Ahead	*	B	48 X 48	Orange	Black	1 1/4	3/4	7 - Series C	7 - Series C	7 - Series C	Construction	25	3		X		
XW20-1-A	W20-1	Road Construction Ahead	*	B	60 X 60	Orange	Black	1 1/2	1	8 - Series C	8 - Series C	8 - Series C	Construction	25	3		X		
XW20-1a	W20-1	Road Repairs Next Miles	*	B	48 X 48	Orange	Black	1 1/4	3/4	8 - Series C	8 - Series C	6 - Series C			3		X		
XW20-2	W20-2	Detour Ahead	*	B	48 X 48	Orange	Black	See FHWA publication Standard Highway Signs for fabrication details											X
XW20-3	W20-3	Road Closed Ahead	*	B	48 X 48	Orange	Black	See FHWA publication Standard Highway Signs for fabrication details											X
XW20-4	W20-4	One Lane Road Ahead	*	B	48 X 48	Orange	Black	See FHWA publication Standard Highway Signs for fabrication details											X
XW20-5 (R, C, or	W20-5	Lane Closed Ahead	*	B	48 X 48	Orange	Black	See FHWA publication Standard Highway Signs for fabrication details											X
XW20-7-A	W20-7	Flagger Symbol	*	B	48 X 48	Orange	Black	See FHWA publication Standard Highway Signs for fabrication details											X
XW20-YWR(A)	-	Wide Load Restriction Miles	*	B	48 X 48	Orange	Black	1 1/4	3/4	6 - Series D	6 - Series D	6 - Series D			3		X		
XW20-YWR(B)	-	Wide Load Over ft Must Exit	*	B	48 X 48	Orange	Black	1 1/4	3/4	6 - Series C	6 - Series C	6 - Series C	6 - Series C		3		X		
XW20-YWR(C)	-	No Loads Over ft Wide	*	B	48 X 48	Orange	Black	1 1/4	3/4	6 - Series D	6 - Series D	6 - Series D	6 - Series D		3		X		

*Wood post permitted.

NOTES:

- ① Spacing between letters of this word or line shall be reduced by this percentage as shown in the FHWA document, *Standard Highway Signs*.
- 2. See Standard Drawing E 801-TCSN-01 for additional general notes.
- 3. All dimensions are in inches.

INDIANA DEPARTMENT OF TRANSPORTATION

TRAFFIC CONTROL SIGN DESIGN DETAILS

SEPTEMBER 2016

STANDARD DRAWING NO. E 801-TCSN-05

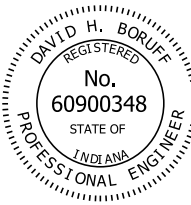
	<p>/s/ <i>David H. Boruff</i> 03/24/16 DESIGN STANDARDS ENGINEER DATE</p> <p>/s/ <i>Mark A. Miller</i> 03/24/16 CHIEF ENGINEER DATE</p>
---	---

① ①

SIGN NUMBER	IMUTCD CODE	SIGN MESSAGE	POST DESIGN		SIGN SIZE	SIGN COLOR		BORDER WIDTH	MARGIN WIDTH	LETTER HEIGHT SERIES - LINE 1	LETTER HEIGHT SERIES - LINE 2	LETTER HEIGHT SERIES - LINE 3	WORD OR LINE	PCT.	CORNER RADIUS	NO. OF POSTS	
			4 X 4 WOOD	STEEL		BACKGROUND	COPY									1	2
XW21-1-A	W21-1	Workers Symbol	*	A	36 X 36	Orange	Black										X
XW21-2	W21-2	Fresh Oil	*	A	30 X 30	Orange	Black									X	
XW21-2-A	W21-2	Fresh Oil	*	A	36 X 36	Orange	Black										X
XW21-3-A	W21-3	Road Machinery Ahead	*	B	48 X 48	Orange	Black										X
W20-1	W20-1	Road Work Ahead	*	B	48 X 48	Orange	Black										X
XW21-5-A	W21-5	Shoulder Work	*	A	36 X 36	Orange	Black										X
XW21-6-A	W21-6	Survey Crew	*	A	36 X 36	Orange	Black										X
XW21-7	W21-7	Utility Work Ahead	*	A	36 X 36	Orange	Black										X
XW21-7-A	W21-7	Utility Work Ahead	*	B	48 X 48	Orange	Black										X
XW21-8a	W21-8	Mowing Crews Ahead	*	A	36 X 36	Orange	Black	3/4	1/2	6 - Series C	6 - Series C	6 - Series C			2 1/4		X
XW21-8a-A	W21-8	Mowing Crews Ahead	*	B	48 X 48	Orange	Black	1 1/4	3/4	8 - Series C	8 - Series C	8 - Series C			3		X
XW21-8b	W21-8	Mowing Crews Next ___ Miles	*	A	36 X 36	Orange	Black	3/4	1/2	6 - Series C	6 - Series C	4 - Series C	4 - Series C		2 1/4		X
XW21-8b-A	W21-8	Mowing Crews Next ___ Miles	*	B	48 X 48	Orange	Black	1 1/4	3/4	8 - Series C	8 - Series C	6 - Series C	6 - Series C		3		X
XW103-1	-	Watch for Stopped Traffic	*	B	48 X 48	Orange	Black	1 1/4	3/4	7 - Series C	7 - Series C	7 - Series C			3		X
XG20-1	G20-1	Road Construction Next ___ Miles	*	B	60 X 36	Orange	Black	3/4	1/2	6 - Series C	6 - Series C	6 - Series C			2 1/4		X
XG20-2	G20-2	End Construction	*	B	60 X 24	Orange	Black	1/2	3/8	6 - Series C	6 - Series C				1 1/2		X
G20-2	G20-2	End Road Work	*	B	48 X 18	Orange	Black										X
XG20-4	G20-4	Pilot Car Follow Me	-	-	36 X 18	Orange	Black									-	-
XG20-5	-	(Route Number or Lane Closed On or After ___)	*	B	60 X 36	Orange	Black	3/4	1/2	6 - Series C	6 - Series C	6 - Series C			2 1/4		X
XG20-5P	XG20-5P	Worksite Plaque	-	-	48 X 16	Orange	Black	1/2	3/8	8 - Series C					1 1/2	-	-
XW20-6	-	Lane Restrictions On or After ___	*	B	60 X 36	Orange	Black	3/4	1/2	5 - Series C	5 - Series C	4 - Series C			1 7/8		X
XW20-6A	-	Lane Restrictions On or After ___	*	B	72 X 36	Orange	Black	7/8	5/8	6 - Series C	6 - Series C	5 - Series C			2 1/4		X
XM4-9 (R or L)	M4-9	Detour (Above Black Arrow)	*	A	30 X 24	Orange	Black									X	
XM4-9-B (R or L)	M4-9	Detour (Above Black Arrow)	*	B	48 X 36	Orange	Black										X
XM4-Y9d	-	___ St / Detour Arrow	*	B	L X 36	Orange	Black	1/2	3/8	4 - Series C	6 - Series C		1	30	1 1/2	X (L ≤ 42)	X (L > 42)
XM4-Y9e	-	___ St / Direction / Detour Arrow	*	B	L X 48	Orange	Black	1/2	3/8	4 - Series C	6 - Series C	6 - Series C	1	30	1 1/2	X (L ≤ 36)	X (L > 36)
XM4-10 (R or L)	M4-10	Detour (Inside Orange Arrow)	*	B	48 X 18	Black & Orange	Black										X
XW105-1-A	-	Right Lane Exit Open	*	B	48 X 48	Orange	Black	1 1/4	3/4	6 - Series C	6 - Series C				3		X
XW106-1-A	-	Exit Closed	*	B	48 X 48	Orange	Black	1 1/4	3/4	7 - Series C	7 - Series C				3		X
XW106-2-A	-	Exit Open	*	B	48 X 48	Orange	Black	1 1/4	3/4	7 - Series C	7 - Series C				3		X
XW109-1	-	Exit (Above Black Arrow)	*	B	48 X 48	Orange	Black										X

*Wood post permitted.

NOTES:

- ① Spacing between letters of this word or line shall be reduced by this percentage as shown in the FHWA document, *Standard Highway Signs*.
- 2. See Standard Drawing E 801-TCSN-01 for additional general notes.
- 3. All dimensions are in inches.

INDIANA DEPARTMENT OF TRANSPORTATION	
TRAFFIC CONTROL SIGN DESIGN DETAILS	
SEPTEMBER 2016	
STANDARD DRAWING NO.	E 801-TCSN-06
	<i>/s/ David H. Boruff</i> 03/24/16 DESIGN STANDARDS ENGINEER DATE
	<i>/s/ Mark A. Miller</i> 03/24/16 CHIEF ENGINEER DATE

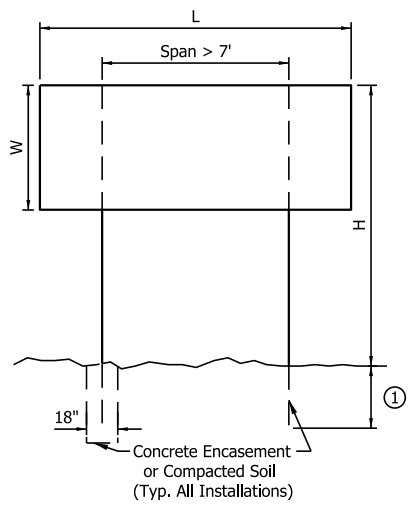

2 - POST INSTALLATION

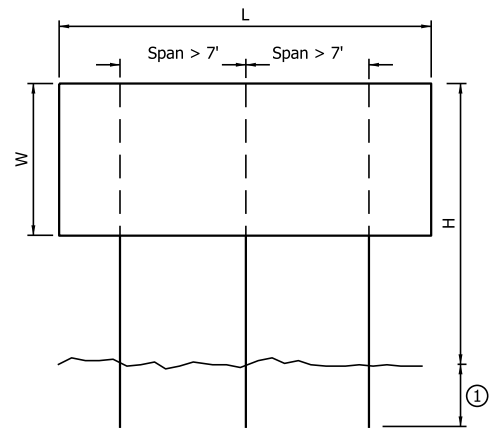

3 - POST INSTALLATION

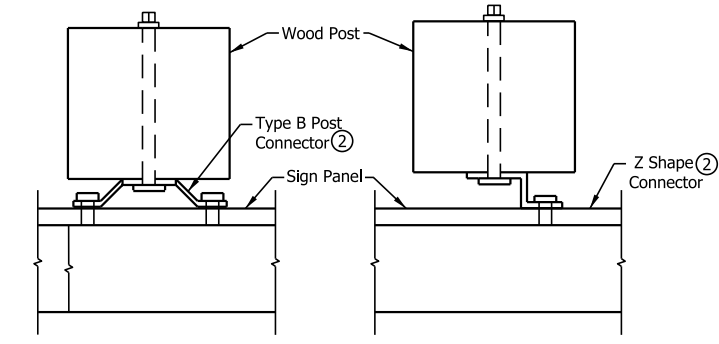
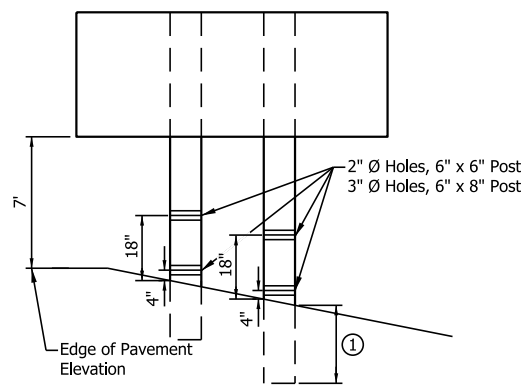

TYPE B POST CONNECTION

Z SHAPE CONNECTION DETAIL

NOTES:

- ① The dimension is $H/10 + 3$ ft or a minimum of 5 ft.
- ② The length of the Type B Post Connector or Z Shape Connector is equal to the length of W.
- 3. See Standard Drawing E 801-TCSN-08 for post size and number of posts required.

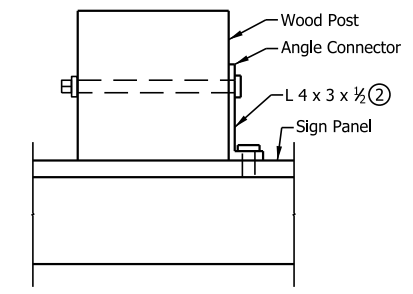

ANGLE SHAPE CONNECTION DETAIL

INDIANA DEPARTMENT OF TRANSPORTATION											
TEMPORARY PANEL SIGN BREAKAWAY POST INSTALLATION											
SEPTEMBER 2016											
STANDARD DRAWING NO.	E 801-TCSN-07										
	<table style="width: 100%; border: none;"> <tr> <td style="border: none;"><i>/s/ David H. Boruff</i></td> <td style="border: none; text-align: right;">02/25/16</td> </tr> <tr> <td style="border: none;">DESIGN STANDARDS ENGINEER</td> <td style="border: none; text-align: right;">DATE</td> </tr> <tr> <td colspan="2" style="border: none;"> </td> </tr> <tr> <td style="border: none;"><i>/s/ Mark A. Miller</i></td> <td style="border: none; text-align: right;">02/25/16</td> </tr> <tr> <td style="border: none;">CHIEF HIGHWAY ENGINEER</td> <td style="border: none; text-align: right;">DATE</td> </tr> </table>	<i>/s/ David H. Boruff</i>	02/25/16	DESIGN STANDARDS ENGINEER	DATE			<i>/s/ Mark A. Miller</i>	02/25/16	CHIEF HIGHWAY ENGINEER	DATE
<i>/s/ David H. Boruff</i>	02/25/16										
DESIGN STANDARDS ENGINEER	DATE										
<i>/s/ Mark A. Miller</i>	02/25/16										
CHIEF HIGHWAY ENGINEER	DATE										

		SIGN LENGTH,L (FT)												
		8	9	10	11	12	13	14	15	16	17	18	19	20
SIGN WIDTH,W (FT)	4													
	5			2-6" X 6"										
	6								2-6" X 8"					
	7								3-6" X 8"					
	8													
	9													
	10													
	11													
	12													
	13													
	14													
	15													
	16													

NOTES:

1. No more than one post can be located in a 7 foot wide path.

INDIANA DEPARTMENT OF TRANSPORTATION

WOOD POST DESIGN FOR
TEMPORARY PANEL SIGNS

SEPTEMBER 2016

STANDARD DRAWING NO. E 801-TCSN-08

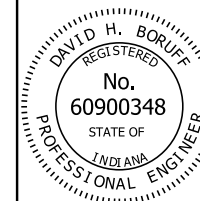

/s/ David H. Boruff 02/25/16
DESIGN STANDARDS ENGINEER DATE

/s/ Mark A. Miller 02/25/16
CHIEF ENGINEER DATE